

DC Linear type
Preliminary

SMJQ-D12W04PA-XX

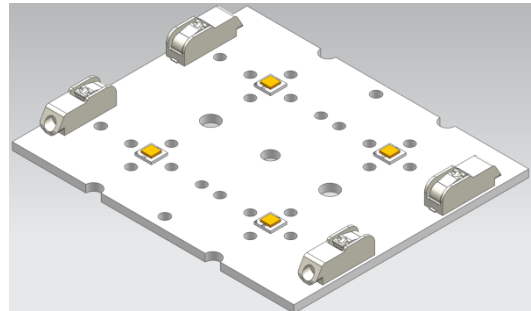

Product Brief

Description

- This module is based on the latest Wico p technology and it's ideal for a high lum en per square millimeter
- The module is designed to fit with CSP array lenses from LEDIL
- Easy to mount inside a small luminaries this module provides the highest lm/w in the market of high power

Features and Benefits

- Allow the slim design
- Best uniformity
- Lead Free product
- RoHS compliant

Key Applications

- Outdoor

Table 1-1. Product Selection - FLUX

Bin	Flux			Unit	CRI
	Min.	Typ.	Max.		
B26	-	1260	-	lm	70

Table 1-2. Product Selection - CCT

Bin	CCT	Unit
EC4	4,000	K

Table 1-3. Product Selection – CRI and Vf

Bin	CRI	Vf [V]	Current [mA]
7G00	70	12	700

Table of Contents

Index	
• Product Brief	
• Table of Contents	
• Performance Characteristics	
• Thermal Resistance	
• Color Bin Structure	
• Mechanical Dimensions	
• Circuit Drawing	
• Marking Information	
• Packing & Label Information	
• Precaution for Use	
• Company Information	

Performance Characteristics

Table 2. Electro Optical Characteristics, T_a = 25°C

Parameter	Symbol	Value			Unit	Mark
		Min.	Typ.	Max.		
Luminous Flux	Φ_V ^[2]	-	1260	-	lm	B26
Correlated Color Temperature ^[3]	CCT	3700	4000	4200	K	E
CRI	Ra	70	-	-	-	-
Input Voltage ^[4]	V _{in}		12		Vdc	
Viewing Angle	2 $\Theta_{1/2}$		140		deg.	

Notes :

- (1) At 700mA, T_a = 25°C
- (2) Φ_V is the total luminous flux output measured with an integrated sphere.
- (3) Correlated Color Temperature is derived from the CIE 1931 Chromaticity diagram.
- (4) Operating Voltage doesn't indicate the maximum voltage which customers use but means tolerable voltage according to each country's voltage variation rate. It is recommended that the solder pad temperature should be below 70°C.
- (5) LED PKG Sorting condition : IF = 700mA, T_j = 85°C

Absolute Maximum Ratings

Table 3. Absolute Maximum Ratings, $T_a = 25^\circ\text{C}$

Parameter	Symbol	Unit	Value
Maximum Input Current	I_{in}	mA	1000
Voltage	V	Vdc	14
Operating Temperature	T_{opr}	$^\circ\text{C}$	-30 ~ 85
Storage Temperature	T_{stg}	$^\circ\text{C}$	-40 ~ 100
ESD Sensitivity	-	-	$\pm 4,000\text{V HBM}$

Thermal Resistance

Part	Package Power Dissipation [W]	Maximum Junction Temp[°C]	R θ_{j-s} [°C/W]
LED	SZ8-Y22-WX-C7-P Max 6.5	145	4.0

The LED has a thermal resistance of 4.0°C/W from junction of the LED to the LED lead.

The maximum junction temperature of the WICOP LED is 145°C, therefore the maximum lead temperature T_{s_max} is

$$\begin{aligned}
 T_{s_max} &= T_{j_max} - (R_{q_{j-s}} * P_D) \\
 &= 145^\circ\text{C} - (4.0^\circ\text{C/W} * 6.5\text{W}) = 119^\circ\text{C}
 \end{aligned}$$

Relative Spectral Distribution

Fig 1. Relative Spectral Distribution vs. Wavelength Characteristic – E

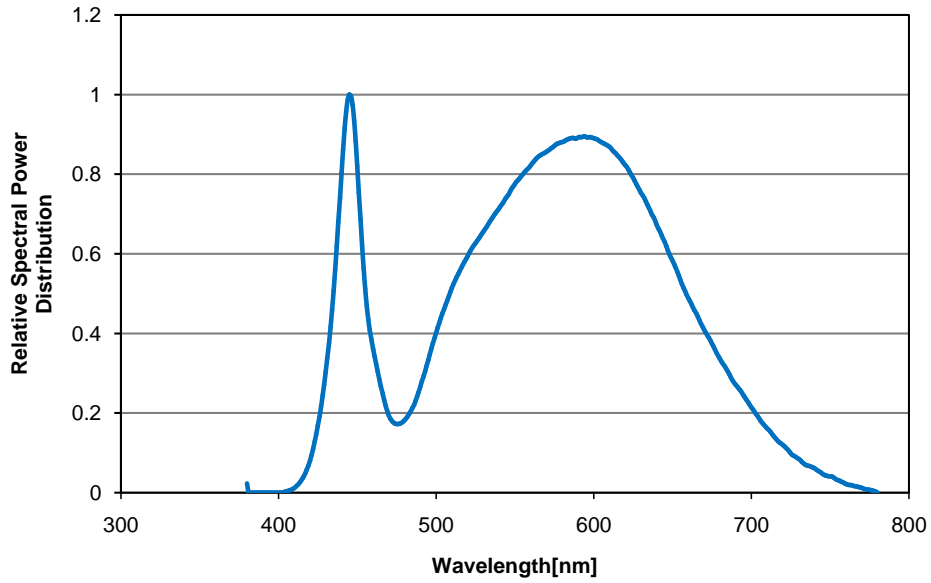

Luminous Flux Characteristics

Fig 2. Spatial Distribution, $T_a = 25^\circ\text{C}$

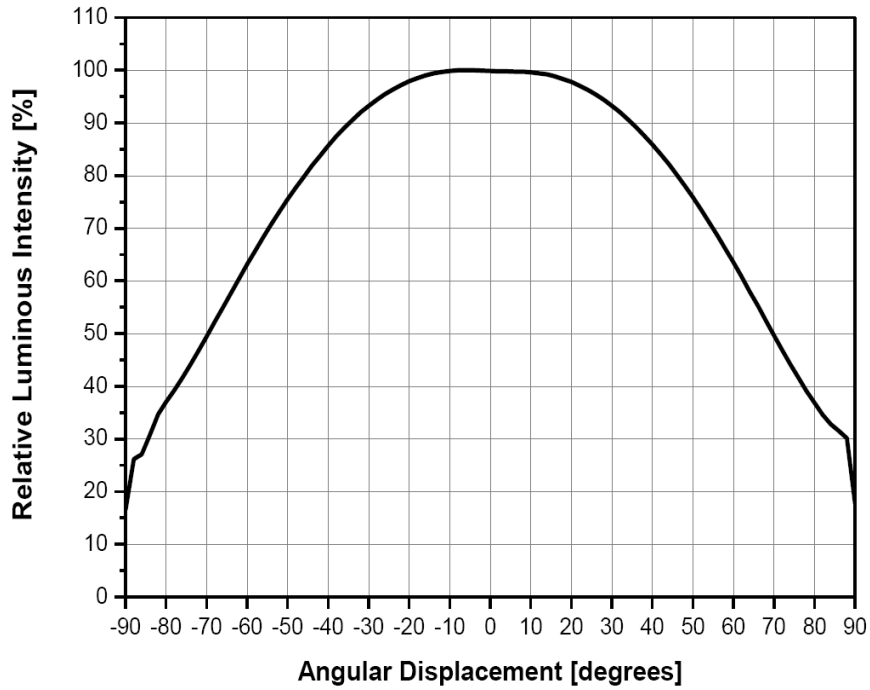

Color Bin Structure

<PKG I_F = 700mA, T_a = 85°C>

CIE Chromaticity Diagram

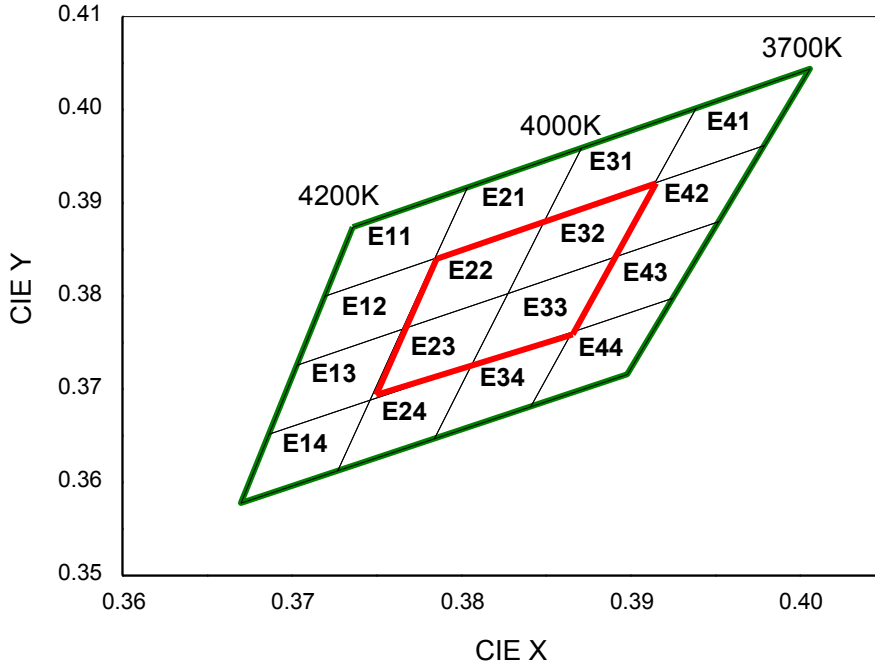

Bin	x	y	Bin	x	y
	0.3784	0.3841		0.3849	0.3881
E22	0.3765	0.3765	E32	0.3828	0.3803
	0.3828	0.3803		0.3890	0.3842
	0.3849	0.3881		0.3914	0.3922
	0.3765	0.3765		0.3828	0.3803
E23	0.3746	0.3689	E33	0.3806	0.3725
	0.3806	0.3725		0.3865	0.3762
	0.3828	0.3803		0.3890	0.3842

Mechanical Dimensions

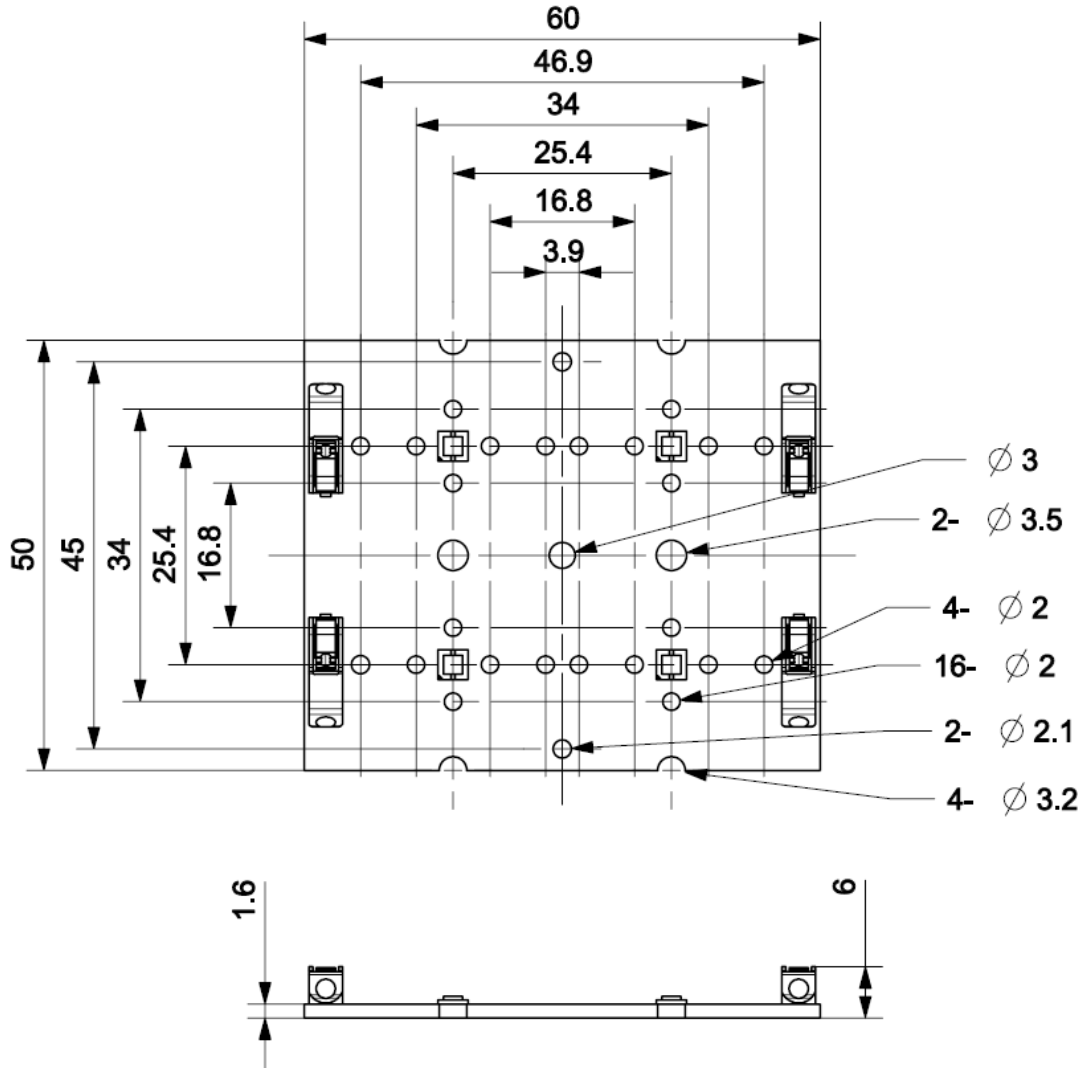
Notes :

- (1) All dimensions are in millimeters.
- (2) Scale : None
- (3) Non define tolerance

Reference	>100	<100
Tolerance	± 0.3	± 0.2

Part List

Table 4. Part List

No	Part	Reference	Specification	Quantity
1	PCB	-	Metal(Al), 60 x 50, 1.6T, White PSR, Yellow silk,	1
2	LED	L1 ~L4	SZ8-Y22-WN-C7-P	4
4	Connector	CN1 ~ CN4	Wago 2060-451	4
5	TVS	Z1	SMF16A (Littelfuse)	1

Circuit Drawing

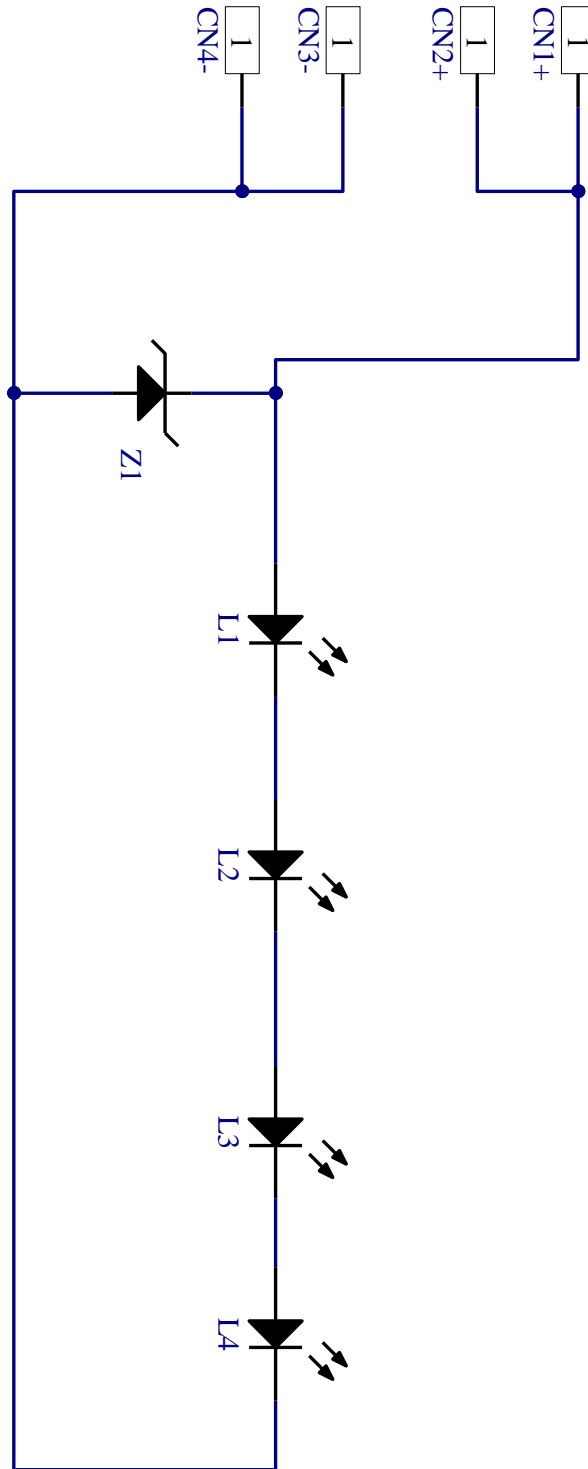

Marking Information

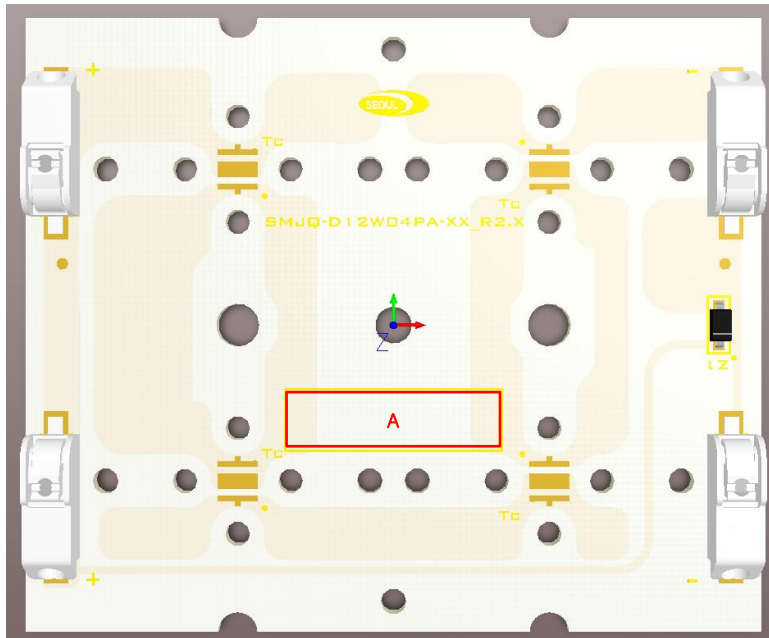
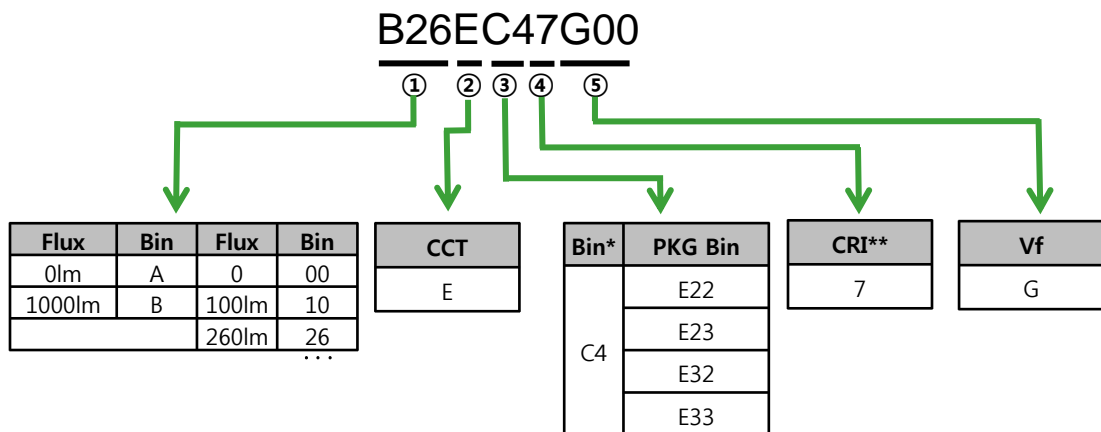

Fig 1. 2D Marking point (In Yellow Box → A Location)



- ① SMT Date (YYMMDD, 6 Digits)
- ② MP Information (10 Digits)
- ③ Lot Number (6 Digits)

Table 1. MP information



* C4 = Center 4 bin

** 7 : CRI70

Packing

1. Tray information

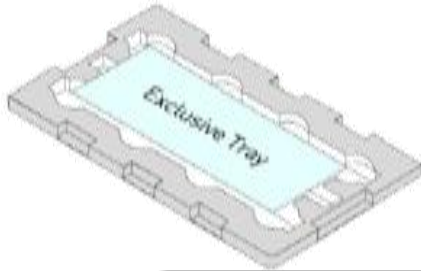

4. Box information & packing

• 6 P

2. T

- 20
- tray
- Ac

3. S

TBD

Packs

Label Information

Model No.	SMJQ-D12W04PA-XX ⁽¹⁾
Rank	B26EC47G00 ⁽²⁾
Type	EC4 ⁽³⁾
Quantity	XX
Lot No.	YYMDDXXXXXX-XXXXXXX
	SEOUL SEMICONDUCTOR CO.,LTD.

Notes

- (1) The model number designation is explained as follow
 SMJQ : Seoul Semiconductor internal code
 D12W : 12V DC WICOP Module
 04P : Y22P WICOP 4pcs
 A : A type
- (2) It represents the LED module rank.
 B26 : Module Flux Bin(B26 = 1,260 lm)
 E : CCT
 7 : CRI70
 C4 : Module CCT Bin (Center 4Bin)
 G00 : PKG Vf G rank
- (3) EC4 : E rank Center4 Bin
- (4) It is attached to the top of a sealing pack & the bottom right corner of the box.

<p>TOTAL Quantity</p> <p> </p> <p>XX</p>
 SEOUL SEMICONDUCTOR CO.,LTD.

Notes

- (1) It is attached to the bottom right corner of the box.

Handling of Silicone Resin for LEDs

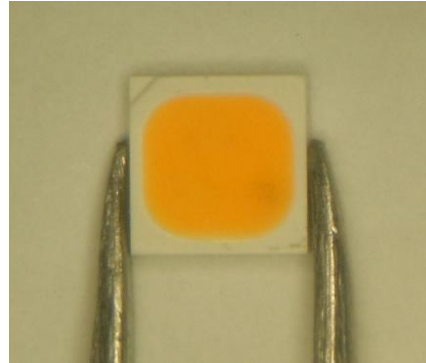
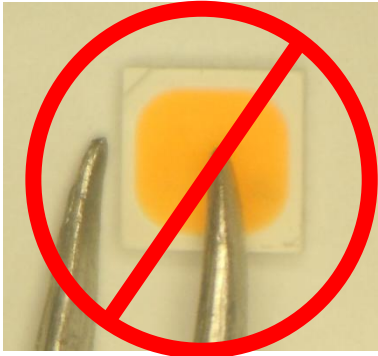

- (1) Acrich3 series is encapsulated with silicone resin for high optical efficiency.
- (2) Please do not touch the silicone resin area with sharp objects such as pincette(tweezers).
- (3) Finger prints on silicone resin area may affect the performance.
- (4) Please store LEDs in covered containers to prevent dust accumulation as this may affect performance.
- (5) Excessive force more than 3000gf to the silicone lens can result in fatal or permanent damage with LEDs.
- (6) Please do not cover the silicone resin area with any other resins such as epoxy, urethane, etc.

Precaution for Use

- (1) Please review the Acrich3 Application Note for proper protective circuitry usage.
- (2) Please note, Acrich3 products run off of high voltage, therefore caution should be taken when working near Acrich3 products.
- (3) Make sure proper discharge prior to starting work.
- (4) DO NOT touch any of the circuit board, components or terminals with body or metal while circuit is active.
- (5) Please do not add or change wires while Acrich3 circuit is active.
- (6) Long time exposure to sunlight or UV can cause the lens to discolor.
- (7) Please do not use adhesives to attach the LED that outgas organic vapor.
- (8) Please do not use together with the materials containing Sulfur.
- (9) Please do not assemble in conditions of high moisture and/or oxidizing gas such as Cl, H₂S, NH₃, SO₂, NO_x, etc.
- (10) Please do not make any modification on module.
- (11) Please be cautious when soldering to board so as not to create a short between different trace patterns.
- (12) Do not impact or place pressure on this product because even a small amount of pressure can damage the product. The product should also not be placed in high temperatures, high humidity or direct sunlight since the device is sensitive to these conditions.
- (13) When storing devices for a long period of time before usage, please following these guidelines:
 - * The devices should be stored in the anti-static bag that it was shipped in from Seoul-Semiconductor with opening.
 - * If the anti-static bag has been opened, re-seal preventing air and moisture from being present in the bag.
- (14) LEDs and IC are sensitive to Electro-Static Discharge (ESD) and Electrical Over Stress (EOS). The Acrich3 product should also not be installed in end equipment without ESD protection. Below is a list of suggestions that Seoul Semiconductor purposes to minimize these effects.

a. ESD (Electro Static Discharge)

Electrostatic discharge (ESD) is the defined as the release of static electricity when two objects come into contact. While most ESD events are considered harmless, it can be an expensive problem in many industrial environments during production and storage. The damage from ESD to an LEDs may cause the product to demonstrate unusual characteristics such as:

Precaution for Use

- Increase in reverse leakage current lowered turn-on voltage
- Abnormal emissions from the LED at low current

The following recommendations are suggested to help minimize the potential for an ESD event. One or more recommended work area suggestions:

- Ionizing fan setup
- ESD table/shelf mat made of conductive materials
- ESD safe storage containers

One or more personnel suggestion options:

- Antistatic wrist-strap
- Antistatic material shoes
- Antistatic clothes

Environmental controls:

- Humidity control (ESD gets worse in a dry environment)

b. EOS (Electrical Over Stress)

Electrical Over-Stress (EOS) is defined as damage that may occur when an electronic device is subjected to a current or voltage that is beyond the maximum specification limits of the device. The effects from an EOS event can be noticed through product performance like:

- Changes to the performance of the LED package
(If the damage is around the bond pad area and since the package is completely encapsulated the package may turn on but flicker show severe performance degradation.)
- Changes to the light output of the luminaire from component failure
- Components on the board not operating at determined drive power

Failure of performance from entire fixture due to changes in circuit voltage and current across total circuit causing trickle down failures. It is impossible to predict the failure mode of every LED exposed to electrical overstress as the failure modes have been investigated to vary, but there are some common signs that will indicate an EOS event has occurred:

- Damaged may be noticed to the bond wires (appearing similar to a blown fuse)
- Damage to the bond pads located on the emission surface of the LED package
(shadowing can be noticed around the bond pads while viewing through a microscope)
- Anomalies noticed in the encapsulation and phosphor around the bond wires
- This damage usually appears due to the thermal stress produced during the EOS event

c. To help minimize the damage from an EOS event Seoul Semiconductor recommends utilizing:

- A surge protection circuit
- An appropriately rated over voltage protection device
- A current limiting device



Company Information

Published by

Seoul Semiconductor © 2013 All Rights Reserved.

Company Information

Seoul Semiconductor (SeoulSemicon.com) manufactures and packages a wide selection of light emitting diodes (LEDs) for the automotive, general illumination/lighting, appliance, signage and back lighting markets. The company is the world's fifth largest LED supplier, holding more than 10,000 patents globally, while offering a wide range of LED technology and production capacity in areas such as "nPola", deep UV LEDs, "Acrich", the world's first commercially produced AC LED, and "Acrich MJT - Multi-Junction Technology" a proprietary family of high-voltage LEDs. The company's broad product portfolio includes a wide array of package and device choices such as Acrich, high-brightness LEDs, mid-power LEDs, side-view LEDs, through-hole type LED lamps, custom displays, and sensors. The company is vertically integrated from epitaxial growth and chip manufacture in its fully owned subsidiary, Seoul Viosys, through packaged LEDs and LED modules in three Seoul Semiconductor manufacturing facilities. Seoul Viosys also manufactures a wide range of unique deep-UV wavelength devices.

Legal Disclaimer

Information in this document is provided in connection with Seoul Semiconductor products. With respect to any examples or hints given herein, any typical values stated herein and/or any information regarding the application of the device, Seoul Semiconductor hereby disclaims any and all warranties and liabilities of any kind, including without limitation, warranties of non-infringement of intellectual property rights of any third party. The appearance and specifications of the product can be changed to improve the quality and/or performance without notice.